

	GSE – PROMOTE 2 C6 Validation Report	REF : PROMOTE 2 C6 ISSUE : 1.0 DATE : 25.05.2007 PAGE : 1
--	--	--

DOSSIER: COMMON	TASK: -2-
-----------------	-----------



TITLE:

**GMES SERVICE ELEMENT
PROMOTE 2**

**C6 Validation Report
SUPPORT TO AVIATION CONTROL SERVICE
(SACS)
VERSION 1**

	GSE – PROMOTE 2 C6 Validation Report SACS	REF : PROMOTE 2 C6 ISSUE : 1.0 DATE : 25.05.2007 PAGE : II
---	--	---

DOCUMENT STATUS SHEET

	FUNCTION	NAME	DATE	SIGNATURE
LEAD AUTHORS	editor	R. Delgado J. C. Lambert		
CONTRIBUTING AUTHORS	Service leader Service providers	J. van Geffen P. Valks	09.05.2007	
REVIEWED BY	Reviewers			
APPROVED BY	Technical officer (ESA)			
ISSUED BY	Project manager			



GSE - PROMOTE 2

C6 Validation Report
SACS

REF: PROMOTE-2 C6
ISSUE: 1.0
DATE: 25.05.2007
PAGE: III

DOCUMENT CHANGE RECORD

Issue	Date	Modified Items / Reason for Change
Version 1		
0.1	22.02.2007	Document created and sent
0.2	09.03.2007	Document updated
0.3	05.04.2007	Revision S5
0.4	30.04.2007	Document formatted and sent
0.5	09.05.2007	Document filled in as far as currently possible
0.6	25.05.2007	Document edited
0.9	25.05.2007	Document links and properties updated
1.0	25.06.2007	Document properties updated

	GSE - PROMOTE 2 C6 Validation Report SACS	REF: PROMOTE-2 C6 ISSUE: 1.0 DATE: 25.05.2007 PAGE: IV
---	--	---

LIST OF TABLES

Table 1.2-1 Characterization of products provided by the Support to Aviation Control Service (SACS)	3
Table 1.3-1 Validation data for SACS Service and products.	4
Table 1.4-1 Validation of individual components for the SO ₂ slant and vertical column densities based on SCIAMACHY data.	5
Table 1.4-2 Validation against specifications and against user requirements of SCIAMACHY SO ₂ slant and vertical column densities	7
Table 1.4-3 Quality assessment and control procedures for SCIAMACHY SO ₂ slant and vertical column densities	7
Table 1.5-1 Validation of individual components of SO ₂ vertical column densities based on OMI data	8
Table 1.5-2 Validation against specifications and against user requirements of SO ₂ vertical column densities based on OMI data.....	10
Table 1.5-3 Quality assessment and control procedures for OMI SO ₂ slant and vertical column densities	10
Table 1.6-1 Validation of the individual components for the Volcanic Ash Indicator	11
Table 1.6-2 Validation against specifications and against user requirements for the Volcanic Ash Indicator.....	12
Table 1.6-3 Quality assessment and control procedures for the Volcanic Ash Indicator.....	13
Table 1.7-1 Validation of individual components for trajectories.....	13
Table 1.7-2 Validation against specifications and against user requirements for trajectories.....	15
Table 1.7-3 Validation of Quality assessment and control procedures for the product Trajectories.....	15
Table 1.8-1 Validation of individual components for E-mail notifications and dedicated webpages...	16
Table 1.8-2 Validation against specifications and against user requirements for e-mail notifications and dedicated webpages	17
Table 1.8-3 Validation of Quality assessment and control procedures for e-mail and dedicated web pages.....	18

 The logo for PROMOTE features a stylized graphic of three colored spheres (red, green, yellow) connected by lines to a horizontal bar, with the word "PROMOTE" in blue capital letters below it.	GSE - PROMOTE 2 C6 Validation Report SACS	REF: PROMOTE-2 C6 ISSUE: 1.0 DATE: 25.05.2007 PAGE: V
--	--	--

LIST OF FIGURES

Figure 1.1-1 Structure of the Special PROMOTE 2 Service for Support to Aviation Control (SACS).. 1

	GSE - PROMOTE 2 C6 Validation Report SACS	REF: PROMOTE-2 C6 ISSUE: 1.0 DATE: 25.05.2007 PAGE: VI
---	--	---

LIST OF ACRONYMS

AMF	Air-Mass Factor
BIRA-IASB	Belgian Institute for Space Aeronomy
BrO	Bromine Oxide
CGS	Carlo Gavazzi Space
CO	Carbon Monoxide
DLR	German Aerospace Center
DOAS	Differential Optical Absorption Spectrometry
DU	Dobson Unit
ECMWF	European Centre for Medium-range Weather Forecast
ENVISAT	Environmental Satellite (ESA)
EOS-Aura	Earth Observing System - Chemistry & Climate Mission (NASA)
ERS-2	European Remote Sensing Satellite (ESA)
ESA	European Space Agency
ESRIN	European Space Research Institute
EUMETSAT	European Organisation for the Exploitation of Meteorological Satellites
FRESCO	Fast Retrieval Scheme for Cloud Observables
GOME	Global Ozone Monitoring Instrument (aboard ERS-2)
GOME-2	Global Ozone Monitoring Instrument (aboard MetOp-A)
H ₂ SO ₄	Sulphuric acid
IAVW	International Airways Volcano Watch
ICAO	International Civil Aviation Organization
KNMI	Royal Netherlands Meteorological Institute
LIDORT	Linearized Discrete Ordinate RTM
MetOp-A	Meteorological Operational Satellite (Eumetsat)
MSG	Meteosat Second Generation (Eumetsat)
N/A	Not Applicable
NASA	National Aeronautics and Space Administration
NRT	Near-Real Time
OMI	Ozone Monitoring Instrument (aboard EOS-Aura)
PROMOTE	Protocol Monitoring for the GMES Service Element: Atmosphere
SACS	Support to Aviation Control Service
SCIAMACHY	SCanning Imaging Absorption spectroMeter for Atmospheric Cartography (aboard ENVISAT)
SCD	Slant Column Density
SEVIRI	Spinning Enhanced Visible and Infrared Imager (aboard MSG)
SO ₂	Sulphur Dioxide
SZA	Solar Zenith Angle
TBC	To Be Confirmed
TBD	To Be Defined / Described
TEMIS	Tropospheric Emission Monitoring Internet Service
VAAC	Volcanic Ash Advisory Centre
VCD	Vertical Column Density
N/A	Not Available
n.a.	not applicable
n.s.	not specified

	GSE - PROMOTE 2 C6 Validation Report SACS	REF: PROMOTE-2 C6 ISSUE: 1.0 DATE: 25.05.2007 PAGE: VII
---	--	--

TABLE OF CONTENTS

DOCUMENT STATUS SHEET	II
DOCUMENT CHANGE RECORD	III
LIST OF TABLES.....	IV
LIST OF FIGURES.....	V
LIST OF ACRONYMS.....	VI
1 SUPPORT TO AVIATION CONTROL SERVICE (SACS).....	VIII
1.1 Service Summary	1
1.2 Product characterization	2
1.3 Validation plan and validation data.....	3
1.4 SO ₂ slant and vertical column densities based on SCIAMACHY data	5
1.4.1 Validation of individual components.....	5
1.4.2 Validation against specifications and user requirements	5
1.4.3 Quality assessment and control procedures for SCIAMACHY SO ₂ slant and vertical column densities.....	7
1.5 SO ₂ vertical column densities based on OMI data.....	8
1.5.1 Validation of individual components.....	8
1.5.2 Validation against specifications and against user requirements.....	8
1.5.3 Quality assessment and control procedures for OMI SO ₂ slant and vertical column densities	10
1.6 Volcanic ash indicator	11
1.6.1 Validation of individual components.....	11
1.6.2 Validation against specifications and against user requirements.....	11
1.6.3 Quality assessment and control procedures for the Volcanic Ash Indicator.....	12
1.7 Trajectories, backward and forward, from peak SO ₂ concentrations	13
1.7.1 Validation of individual components.....	13
1.7.2 Validation against specifications and against user requirements.....	14
1.7.3 Quality assessment and control procedures	15
1.8 E-mail notifications of exceptional SO ₂ concentrations	16
1.8.1 Validation of individual components.....	16
1.8.2 Validation against specifications and against user requirements.....	16
1.8.3 Quality assessment and control procedures	18
1.9 References	18
1.9.1 Electronic references and online data access paths.....	18
1.9.2 Bibliographic references	18



GSE - PROMOTE 2
C6 Validation Report

REF: PROMOTE-2 C6
ISSUE: 1.0
DATE: 25.05.2007
PAGE: VIII

<PAGE INTENTIONALLY LEFT BLANK>

	<p align="center">GSE - PROMOTE 2 C6 Validation Report SACS</p>	<p>REF: PROMOTE-2 C6 ISSUE: 1.0 DATE: 25.05.2007 PAGE: 1 of 19</p>
---	--	---

1 SUPPORT TO AVIATION CONTROL SERVICE (SACS)

1.1 Service Summary

This Special Service consists in the delivery in near-real-time of data derived from satellite measurements regarding SO₂ and aerosol emissions possibly related to volcanic eruptions, and where possible to track volcanic plumes. On the basis of selection criteria of exceptional SO₂ emissions, notifications will be sent by e-mail to interested parties, with a reference to specific pages at the website.

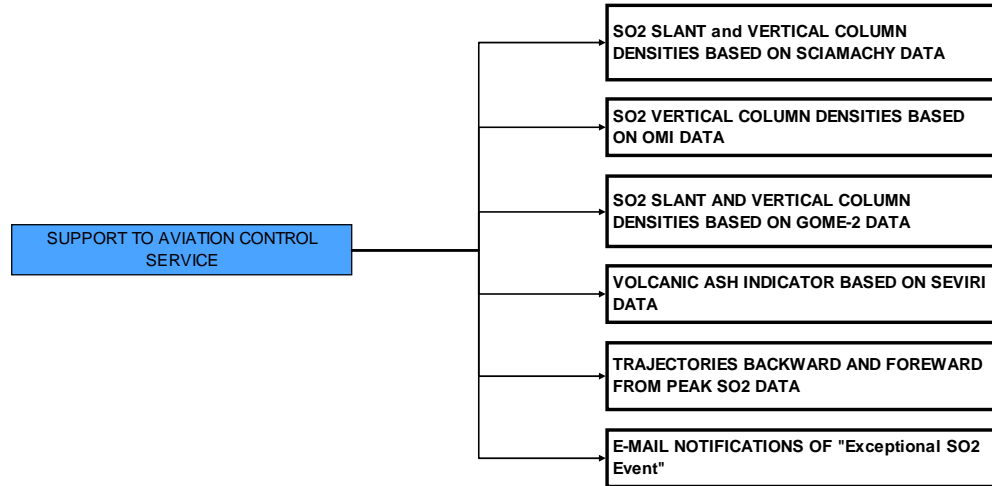

Figure 1.1-1 Structure of the Special PROMOTE 2 Service for Support to Aviation Control (SACS).

Service is/will be operational since/after: First element of the service operational since February 2007, the rest will follow in the course of this and the next phase.

Provider(s): Belgian Institute for Space Aeronomy (BIRA-IASB)

Service Partners: Royal Netherlands Meteorological Institute (KNMI), Carlo Gavazzi Space (CGS), German Aerospace Center (DLR)

Validation contact: Jos van Geffen (BIRA-IASB)

This service is devoted to detect and map volcanic abrasive ashes and corrosive sulfur compounds that represent a major hazard for aviation. A warning system based on the automatic delivery of alert email is also a product of this service.

	GSE - PROMOTE 2 C6 Validation Report SACS	REF: PROMOTE-2 C6 ISSUE: 1.0 DATE: 25.05.2007 PAGE: 2 of 19
---	--	--

1.2 Product characterization

SO₂ slant and vertical column densities based on SCIAMACHY data	
Parameter	SACSCI-SP-GSE-PRO2
Typical range	n.s.
Determination of the typical range (Method, criteria)	n.a.
Units	Dobson Units (DU)
<i>Standards</i>	<i>n.a.</i>
SO₂ vertical column densities based on OMI data	
Parameter	SACOMI-SP-GSE-PRO2
Typical range	n.s.
Determination of the typical range (Method, criteria)	n.a.
Units	Dobson Units (DU)
<i>Standards</i>	<i>n.a.</i>
SO₂ slant and vertical column densities based on GOME-2 data	
Parameter	SACGM2-SP-GSE-PRO2
Typical range	n.s.
Determination of the typical range (Method, criteria)	n.a.
Units	Dobson Units (DU)
<i>Standards</i>	<i>n.a.</i>
Volcanic ash indicator based on SEVIRI data	
Parameter	SACSEV-SP-GSE-PRO2
Typical range	n.s.
Determination of the typical range (Method, criteria)	n.a.
Units	N/A

	GSE - PROMOTE 2 C6 Validation Report SACS	REF: PROMOTE-2 C6 ISSUE: 1.0 DATE: 25.05.2007 PAGE: 3 of 19
--	--	--

<i>Standards</i>	<i>n.a.</i>
Trajectories, backward and forward, from peak SO2 concentrations	
Parameter	SACTRA-SP-GSE-PRO2
Typical range	<i>n.a.</i>
Determination of the typical range (Method, criteria)	<i>n.a.</i>
Units	<i>n.a.</i>
<i>Standards</i>	<i>n.a.</i>
E-mail notifications of “exceptional SO2 concentrations”	
Parameter	SACEML-SP-GSE-PRO2
Typical range	<i>n.a.</i>
Determination of the typical range (Method, criteria)	<i>n.a.</i>
Units	<i>n.a.</i>
<i>Standards</i>	<i>n.a.</i>

Table 1.2-1 Characterization of products provided by the Support to Aviation Control Service (SACS)

1.3 Validation plan and validation data

At this stage of the service, quantitative validation of the different products is not possible due to technical and operational reasons. Therefore, the validation of the SACS service will focus on the demonstration for a sufficient amount of past volcanic eruptions in long-term satellite records.

Validation data is not available at the moment. Future datasets obtained in the framework of the project NOVAC will be used for quantitative validation when existing.

VALIDATION DATA	
Ground based observations	
	N/A
<i>In-situ</i> observations	
	N/A

	<p>GSE - PROMOTE 2 C6 Validation Report SACS</p>	<p>REF: PROMOTE-2 C6 ISSUE: 1.0 DATE: 25.05.2007 PAGE: 4 of 19</p>
---	---	---

<p>Model outputs</p>
<p>N/A</p>
<p>Other Satellite data</p>
<p>N/A</p>

Table 1.3-1 Validation data for SACS Service and products.

	GSE - PROMOTE 2 C6 Validation Report SACS	REF: PROMOTE-2 C6 ISSUE: 1.0 DATE: 25.05.2007 PAGE: 5 of 19
---	--	--

1.4 SO₂ slant and vertical column densities based on SCIAMACHY data

1.4.1 Validation of individual components

SO₂ slant column data is derived with a DOAS technique from measurements by SCIAMACHY. Combining this data with an appropriate air-mass-factor (AMF) gives SO₂ total vertical column data.

VALIDATION OF INDIVIDUAL COMPONENTS [SACSCI-SP-GSE-PRO2]	
Quality assessment	
N/A	
MODELS/ALGORITHMS	
Comparison with other Satellite SO ₂ data	N/A
Comparison with ground-based observations	N/A

Table 1.4-1 Validation of individual components for the SO₂ slant and vertical column densities based on SCIAMACHY data.

1.4.2 Validation against specifications and user requirements

*Requirements written in *Italics* are only recommended and not compulsory for Phase 1

VALIDATION AGAINST SERVICE SPECIFICATIONS [SACSCI-SP-GSE-PRO2]			
No limitations/delays for compliance between theoretical and actual service specifications given in S5 for the product named above have been reported.			
VALIDATION AGAINST USER REQUIREMENTS [SACSCI-SP-GSE-PRO2]			
SPECIFICATION	S5	REQUIRED*	ACTUAL
Parameter	SO ₂ slant and vertical column densities		
Accuracy	n.s.	n.s.	N/A
Accuracy minimum	n.s.	n.s.	N/A
Accuracy target	0-2 DU depending mostly on SZA, actual SO ₂ content and	n.s.	0-2 DU depending mostly on SZA, actual SO ₂

	GSE - PROMOTE 2 C6 Validation Report SACS	REF: PROMOTE-2 C6 ISSUE: 1.0 DATE: 25.05.2007 PAGE: 6 of 19
--	--	--

	clouds		content and clouds
Spatial coverage	Satellite orbits (level-2) and global (level-3)/Identification of active areas	Global/selected areas with volcanic eruptions after 1800	Satellite orbits (level-2) and global (level-3)/Identification of active areas
Horizontal resolution	30x60 Km2	n.s.	30x60 Km2
Vertical resolution	n.s.	n.s.	n.a.
Grid/Projection	Level-1: Orbit geometry (swath 960Km, 6 days global) Level-2: Lat-Long	n.s.	Level-1: Orbit geometry (swath 960Km, 6 days global) Level-2: Lat-Long
Temporal coverage	2003-Now	n.s.	2003-Now
Temporal resolution	Level-1: 6 days global Level-2: daily, 3-daily, monthly	n.s.	Level-1: 6 days global Level-2: daily, 3-daily, monthly
Availability	Since August 2006	n.s.	Since August 2006
User Interfaces			
PROMOTE Web	Complete, operational and up-to-date	Complete; operational and up to date	Complete, operational and up to date
ftp	n.a.	n.a.	n.a.
Data formats and data delivery			
Data access	Dedicated webpages with links to data files and images	Dedicated webpages with links to data files and images	http://sacs.aeronomie.be/ http://www.gse-promote.org
Delivery Mode	Offline: Level-2 and Level-3 data NRT: Level-2 data	NRT and off-line (archived data)	Offline: Level-2 and Level-3 data NRT: Level-2 data
Delivery frequency	At every SO ₂ event	At every SO ₂ event	On event
Historical archive	2003-end	During SCIAMACHY operational life	2003-end
Data Format	HDF, ASCII	HDF, ASCII	HDF, ASCII

	GSE - PROMOTE 2 C6 Validation Report SACS	REF: PROMOTE-2 C6 ISSUE: 1.0 DATE: 25.05.2007 PAGE: 7 of 19
--	--	--

Visualization	Global and regional maps (gif)	GIF	Global and regional maps (gif)
Remarks			
No remarks.			

*Requirements written in *Italics* are only recommended and not compulsory for Phase 1

Table 1.4-2 Validation against specifications and against user requirements of SCIAMACHY SO₂ slant and vertical column densities

1.4.3 Quality assessment and control procedures for SCIAMACHY SO₂ slant and vertical column densities

Service Quality			
SPECIFICATION	S5	REQUIRED	ACTUAL
Quality checks	n.s.	n.s.	n.s.
Product confidence data	n.s.	n.s.	n.s.
Error bar definition and representation	n.s.	n.s.	n.s.
Representation of missing data	n.s.	n.s.	n.s.
Documentation of process failure	n.s.	n.s.	n.s.
Version control mechanisms and representation	n.s.	n.s.	n.s.

*Requirements written in *Italics* are only recommended and not compulsory for Phase 1

Table 1.4-3 Quality assessment and control procedures for SCIAMACHY SO₂ slant and vertical column densities

	GSE - PROMOTE 2 C6 Validation Report SACS	REF: PROMOTE-2 C6 ISSUE: 1.0 DATE: 25.05.2007 PAGE: 8 of 19
--	--	--

1.5 SO₂ vertical column densities based on OMI data

Note from the Validation Office: At the moment of the generation of this report no NRT OMI data was made available by NASA and, therefore, the provision of this product is delayed.

1.5.1 Validation of individual components

VALIDATION OF INDIVIDUAL COMPONENTS [SACOMI--SP-GSE-PRO2]	
Quality assessment	
Quality screening of Level-1 data	N/A
DOAS Quality check	
Quantification of DOAS fitting precision	
AMF Quality check	
Estimated SO ₂ Column accuracy	
Comparison with other Satellite SO ₂ data	N/A
Comparison with ground-based observations	N/A

Table 1.5-1 Validation of individual components of SO₂ vertical column densities based on OMI data

1.5.2 Validation against specifications and against user requirements

VALIDATION AGAINST SERVICE SPECIFICATIONS [SACOMI-SP-GSE-PRO2]			
Parameter	SO ₂ vertical column in Dobson Units (DU); Level-2 data files and global and regional maps		
N/A			
VALIDATION AGAINST USER REQUIREMENTS [SACOMI-SP-GSE-PRO2]			
SPECIFICATION	S5	REQUIRED	ACTUAL
Accuracy minimum	n.s.	n.s.	N/A

	GSE - PROMOTE 2 C6 Validation Report SACS	REF: PROMOTE-2 C6 ISSUE: 1.0 DATE: 25.05.2007 PAGE: 9 of 19
---	--	--

Accuracy target	n.s.	n.s.	N/A
Spatial coverage	Orbits (level-2)	Global/selected areas with volcanic eruptions after 1800	Orbits (level-2)
Horizontal resolution	OMI Resolution/Swath width 2200	n.s.	OMI Resolution/Swath width 2200
Vertical resolution	n.a.	n.a.	n.a.
Grid/Projection	Level-1: satellite orbits	n.s.	Level-1: satellite orbits
Temporal coverage	N/A	n.s.	N/A
Temporal resolution	Global coverage in 1 day	n.s.	Global coverage in 1 day
User Interfaces			
PROMOTE Web	N/A	Complete, operational and up-to-date for this product	N/A
ftp	N/A	n.s.	N/A
Other			
Data formats and data delivery			
<u>Data access</u>	http://sacs.aeronomie.be/ http://www.gse-promote.org/	Dedicated webpages with links to data files and images	http://sacs.aeronomie.be/ http://www.gse-promote.org/
Delivery Mode	N/A	NRT and off-line (archived data)	N/A
Delivery frequency	N/A	At every SO ₂ event	N/A
Historical archive	N/A	OMI Operational life	N/A
Data Format	N/A	HDF, ASCII	N/A
Visualization	N/A	GIF	N/A
Remarks			
No remarks.			

	<p align="center">GSE - PROMOTE 2 C6 Validation Report SACS</p>	REF: PROMOTE-2 C6 ISSUE: 1.0 DATE: 25.05.2007 PAGE: 10 of 19
--	--	---

*Requirements written in *Italics* are only recommended and not compulsory for Phase 1

Table 1.5-2 Validation against specifications and against user requirements of SO₂ vertical column densities based on OMI data

1.5.3 Quality assessment and control procedures for OMI SO₂ slant and vertical column densities

Service Quality			
SPECIFICATION	S5	REQUIRED	ACTUAL
Quality checks	n.s.	n.s.	N/A
Product confidence data	n.s.	n.s.	N/A
Error bar definition and representation	n.s.	n.s.	N/A
Representation of missing data	n.s.	n.s.	N/A
Documentation of process failure	n.s.	n.s.	N/A
Version control mechanisms and representation	n.s.	n.s.	N/A

*Requirements written in *Italics* are only recommended and not compulsory for Phase 1

Table 1.5-3 Quality assessment and control procedures for OMI SO₂ slant and vertical column densities

	GSE - PROMOTE 2 C6 Validation Report SACS	REF: PROMOTE-2 C6 ISSUE: 1.0 DATE: 25.05.2007 PAGE: 11 of 19
---	--	---

1.6 Volcanic ash indicator

1.6.1 Validation of individual components

VALIDATION OF INDIVIDUAL COMPONENTS [SACSEV-SP-GSE-PRO2]	
Quality assessment	
N/A	
MODELS/ALGORITHMS	
N/A	

Table 1.6-1 Validation of the individual components for the Volcanic Ash Indicator

1.6.2 Validation against specifications and against user requirements

VALIDATION AGAINST SERVICE SPECIFICATIONS [SACSEV-SP-GSE-PRO2]			
Parameter	Volcanic ash indicator based on SEVIRI data		
N/A			
VALIDATION AGAINST USER REQUIREMENTS [SACSEV-SP-GSE-PRO2]			
SPECIFICATION	S5	REQUIRED	ACTUAL
Accuracy minimum	N/A	n.s.	N/A
Accuracy target	N/A	n.s.	N/A
Spatial coverage	N/A	n.s.	N/A
Horizontal resolution	N/A	n.a.	N/A
Vertical resolution	n.a.	n.a.	N/A
Grid/Projection	N/A	n.s.	N/A
Temporal coverage	N/A	n.s.	N/A
Temporal resolution	N/A	n.s.	N/A
User Interfaces			

	GSE - PROMOTE 2 C6 Validation Report SACS	REF: PROMOTE-2 C6 ISSUE: 1.0 DATE: 25.05.2007 PAGE: 12 of 19
---	--	---

PROMOTE Web	N/A	Complete, operational and up-to-date for this product	N/A
ftp	N/A	n.a.	N/A
Other	N/A	n.a.	N/A
Data formats and data delivery			
Data availability	N/A	On best effort basis	N/A
Data access	http://sacs.aeronomie.be/ http://www.gse-promote.org/	n.s.	N/A
Delivery Mode	NRT and off-line	NRT and off-line (archived data)	N/A
Delivery frequency	NRT	NRT	N/A
Historical archive	n.s.	n.s.	N/A
Data Format	n.s.	n.s.	N/A
Visualization	Maps	n.s.	N/A
Remarks			
No remarks.			

*Requirements written in *Italics* are only recommended and not compulsory for Phase 1

Table 1.6-2 Validation against specifications and against user requirements for the Volcanic Ash Indicator

1.6.3 Quality assessment and control procedures for the Volcanic Ash Indicator

Service Quality			
SPECIFICATION	S5	REQUIRED	ACTUAL
Quality checks	n.s.	n.s.	N/A
Product confidence data	n.s.	n.s.	N/A

	GSE - PROMOTE 2 C6 Validation Report SACS	REF: PROMOTE-2 C6 ISSUE: 1.0 DATE: 25.05.2007 PAGE: 13 of 19
---	--	---

Error bar definition and representation	n.s.	n.s.	N/A
Representation of missing data	n.s.	n.s.	N/A
Documentation of process failure	n.s.	n.s.	N/A
Version control mechanisms and representation	n.s.	n.s.	N/A

*Requirements written in *Italics* are only recommended and not compulsory for Phase 1

Table 1.6-3 Quality assessment and control procedures for the Volcanic Ash Indicator

1.7 Trajectories, backward and forward, from peak SO₂ concentrations

1.7.1 Validation of individual components

VALIDATION OF INDIVIDUAL COMPONENTS [SACTRA-SP-GSE-PRO2]	
Quality assessment	
N/A	
MODELS/ALGORITHMS	
FLEXTRA model	Stohl et. al., 1995; Stohl and Seibert, 1998; Stohl, 1998 http://zardoz.nilu.no/~andreas/flextra+flexpart.html
FLEXPART particle dispersion model	

Table 1.7-1 Validation of individual components for trajectories

	GSE - PROMOTE 2 C6 Validation Report SACS	REF: PROMOTE-2 C6 ISSUE: 1.0 DATE: 25.05.2007 PAGE: 14 of 19
---	--	---

1.7.2 Validation against specifications and against user requirements

VALIDATION AGAINST SERVICE SPECIFICATIONS [SACTRA-SP-GSE-PRO2]			
Parameter	Backward and forward trajectories		
N/A			
VALIDATION AGAINST USER REQUIREMENTS [SACTRA-SP-GSE-PRO2]			
SPECIFICATION	S5	REQUIRED	ACTUAL
Accuracy minimum	N/A	n.s.	N/A
Accuracy target	N/A	n.s.	N/A
Spatial coverage	N/A	n.s.	N/A
Horizontal resolution	N/A	n.s.	N/A
Vertical resolution	N/A	n.s.	N/A
Grid/Projection	N/A	n.s.	N/A
Temporal coverage	N/A	n.s.	N/A
Temporal resolution	N/A	n.s.	N/A
User Interfaces			
PROMOTE Web	N/A	Complete, operational and up-to-date for this product	N/A
ftp	N/A	n.a.	N/A
Other	N/A	n.a.	N/A
Data formats and data delivery			
Data availability	N/A	On best effort basis	N/A
Data access	http://sacs.aeronomie.be/ http://www.gse-promote.org/	Dedicated webpages with links to data files and images	N/A
Delivery Mode	NRT and off-line	NRT and off-line (archived data)	N/A

	GSE - PROMOTE 2 C6 Validation Report SACS	REF: PROMOTE-2 C6 ISSUE: 1.0 DATE: 25.05.2007 PAGE: 15 of 19
--	--	---

Delivery frequency	At every SO ₂ event	At every exceptional SO ₂ density event	N/A
Historical archive	Trajectories related to an exceptional SO ₂ density event	Trajectories related to an exceptional SO ₂ density event	N/A
Data Format	n.s.	n.s.	N/A
Visualization	Maps	n.s.	N/A
Remarks			
No remarks			

*Requirements written in *Italics* are only recommended and not compulsory for Phase 1

Table 1.7-2 Validation against specifications and against user requirements for trajectories

1.7.3 Quality assessment and control procedures

Service Quality			
SPECIFICATION	S5	REQUIRED	ACTUAL
Quality checks	n.s.	n.s.	N/A
Product confidence data	n.s.	n.s.	N/A
Error bar definition and representation	n.s.	n.s.	N/A
Representation of missing data	n.s.	n.s.	N/A
Documentation of process failure	n.s.	n.s.	N/A
Version control mechanisms and representation	n.s.	n.s.	N/A

*Requirements written in *Italics* are only recommended and not compulsory for Phase 1

Table 1.7-3 Validation of Quality assessment and control procedures for the product Trajectories

	GSE - PROMOTE 2 C6 Validation Report SACS	REF: PROMOTE-2 C6 ISSUE: 1.0 DATE: 25.05.2007 PAGE: 16 of 19
--	--	---

1.8 E-mail notifications of exceptional SO₂ concentrations

1.8.1 Validation of individual components

VALIDATION OF INDIVIDUAL COMPONENTS [SACEML-SP-GSE-PRO2]	
Quality Assessment	
n.a.	
MODELS/ALGORITHMS	
N/A	

Table 1.8-1 Validation of individual components for E-mail notifications and dedicated web pages

1.8.2 Validation against specifications and against user requirements

VALIDATION AGAINST SERVICE SPECIFICATIONS [SACEML-SP-GSE-PRO2]			
Parameter	E-mail and dedicated web pages		
No limitations/delays for compliance between theoretical and actual service specifications given in S5 for the product named above have been reported.			
VALIDATION AGAINST USER REQUIREMENTS [SACEML-SP-GSE-PRO2]			
SPECIFICATION	S5	REQUIRED	ACTUAL
Accuracy minimum	n.s.	n.s.	N/A
Accuracy target	n.s.	100%	N/A
Spatial coverage	n.s.	Global	One or more of the regions: Europe&Africa Asia&Australia North&South America North & South Pacific
Horizontal resolution	n.a.	n.a.	n.a.
Vertical resolution	n.a.	n.a.	n.a.
Grid/Projection	n.a.	n.a.	n.a.
Temporal coverage	Exceptional events	n.s.	Jan 2007 on (Event

	GSE - PROMOTE 2 C6 Validation Report SACS	REF: PROMOTE-2 C6 ISSUE: 1.0 DATE: 25.05.2007 PAGE: 17 of 19
--	--	---

			dedicated webpage)
Temporal resolution	Exceptional events	Exceptional events	Exceptional events
User Interfaces			
PROMOTE Web	Complete, operational and up-to-date	Complete, operational and up-to-date	In progress
ftp	n.a.	n.a.	n.a.
On demand	n.a.	n.a.	n.a.
Data formats and data delivery			
Data availability	On event	On best effort basis	On event
Data access	http://sacs.aeronomie.be/ http://www.gse-promote.org/ and event dedicated web page	Dedicated web pages with links to data files and images	http://sacs.aeronomie.be/ http://www.gse-promote.org/ and event dedicated web pag
Delivery Mode	NRT and off-line	NRT and off-line (archived data)	NRT
Delivery frequency	At every SO ₂ event	At every exceptional SO ₂ density event	On event
Historical archive	Past exceptional SO ₂ density event	Past exceptional SO ₂ density event	February 2007-present
Data format	Text (e-mail)	Text (e-mail)	Text (e-mail)
Visualization	Event-specific webpage	Event-specific webpage	Event-specific webpage

*Requirements written in *Italics* are only recommended and not compulsory for Phase 1

Table 1.8-2 Validation against specifications and against user requirements for e-mail notifications and dedicated web pages

	GSE - PROMOTE 2 C6 Validation Report SACS	REF: PROMOTE-2 C6 ISSUE: 1.0 DATE: 25.05.2007 PAGE: 18 of 19
--	--	---

1.8.3 Quality assessment and control procedures

Service Quality			
SPECIFICATION	S5	REQUIRED	ACTUAL
Quality checks	n.s.	n.s.	N/A
Product confidence data	n.a.	n.a.	n.a.
Error bar definition and representation	n.a.	n.a.	n.a.
Representation of missing data	n.s.	n.s.	N/A
Documentation of process failure	n.s.	n.s.	N/A
Version control mechanisms and representation	n.s.	n.s.	N/A

*Requirements written in *Italics* are only recommended and not compulsory for Phase 1

Table 1.8-3 Validation of Quality assessment and control procedures for e-mail and dedicated web pages

1.9 References

1.9.1 Electronic references and online data access paths

<http://sacs.aeronomie.be/>

<http://zardoz.nilu.no/~andreas/flextra+flexpart.html>

1.9.2 Bibliographic references

Eisinger, M. and Burrows, J.P.: "Tropospheric Sulphur Dioxide observed by the ERS-2 GOME Instrument," *Geophys. Res. Lett.*, No. 25, pp. 4177-4180, 1998.

Hofmann, D.J., Bonasoni, P., De Mazière, M., Evangelisti, F., Francois, P., Giovanelli, G., Goldman, A., Goutail, F., Harder, J., Jakoubek, R., Johnston, P., Kerr, J., McElroy, T., McKenzie, R., Mount, G., Pommereau, J.-P., Simon, P., Solomon, S., Stutz, J., Thomas, A., Van Roozendaal, M., and Wu, E.: "Intercomparison of UV/Visible Spectrometers for Measurements of Stratospheric NO₂ for the Network for the Detection of Stratospheric Change," *J. Geophys. Res.*, 100, 16,765-16,791, 1995.

	<p align="center">GSE - PROMOTE 2</p> <p align="center">C6 Validation Report</p> <p align="center">SACS</p>	<p>REF: PROMOTE-2 C6 ISSUE: 1.0 DATE: 25.05.2007 PAGE: 19 of 19</p>
---	--	--

Platt, U.: "Differential optical absorption spectroscopy (DOAS), Air monitoring by Spectroscopic Techniques (M. Sigrist, ed.)", John Wiley & Sons, Inc., pp. 27–84, 1994.

Roscoe, H.K., Johnston, P.V., Van Roozendaal, M., Richter, A., Roscoe, J., et al.: "Slant column measurements of O₃ and NO₂ during the NDSC intercomparison of zenith-sky UV-visible spectrometers in June 1996," *J. Atmos. Chem.*, 32, pp. 281-314, 1999.

Stohl, A., G. Wotawa, P. Seibert, and H. Kromp-Kolb (1995): Interpolation errors in wind fields as a function of spatial and temporal resolution and their impact on different types of kinematic trajectories. *J. Appl. Meteor.* 34, 2149-2165.

Stohl, A., and P. Seibert (1998): Accuracy of trajectories as determined from the conservation of meteorological tracers. *Q. J. Roy. Met. Soc.* 124, 1465-1484.

Stohl, A. (1998): Computation, accuracy and applications of trajectories - a review and bibliography. *Atmos. Environ.* 32, 947-966